



WAG IT!

GAMES

Competitive Dog Sports

Water Skills

Wag It Inc P.O. Box 413, Lincolnville, Maine 04849 (207)789-5126

www.wagitgames.com

Table of Contents

- **Eligibility**
 - Registering dogs
 - Disabled dogs/handlers

- **Trials**
 - Entering a trial
 - Ring specifications
 - Gate policy
 - Briefings
 - Safety

- **Hosts, Judges & Certified Instructors**

- **Class Levels**

- **Class Divisions**

- **Ribbons**

- **Titles and Points**

- **Performance Guidelines**

- **Equipment**

- **Class Descriptions and Rules**
 - Novice Level
 - Skilled Level
 - Proficient Level

- **Scoring**

- **Excusals**

Eligibility

- Dogs must be registered with Wag It Games to enter a trial. Dog registration forms are available on our web site www.wagitgames.com.
- Pure bred and mixed breed dogs over 1 year of age are welcome to participate.
- Dogs that exhibit signs of pain, discomfort, bandages, stitches or illness may not participate.
- Dogs in estrus may not compete or be present on the grounds.
- *Safety First; Dogs under warning in any venue must submit a report for review. Dogs that have been banned in any other venue are not eligible for registration.*

Participation Requirements

Do to safety concerns all handlers and dogs must be in good health and physical condition to participate in Water Skills.

*** Handlers and dogs must be competent and confident swimmers.**

Trials

Entering a trial: A list of trials and seminars can be found at www.wagitgames.com. Hosts will offer Trial Premiums with entry form, release and all pertinent event information. Entries are made through the trial hosts.

*The trial setting is full of smells, sounds and other distractions. Exhibitors should prepare their dogs for the trial environment.

Briefings: A Judges briefing will precede each class

Safety First

Water Toxicity: Handlers should educate themselves about water toxicity and how to treat their dogs. Dogs that drink a significant amount of water may be at potential risk for Water Toxicity.

Dogs must wear life jackets: This allows for the dog to focus on performing the exercise without the need to exert effort to remain afloat.

Handlers may wear life jackets, wet suits, swim fins: Handlers should be confident in the water to safely perform the course swimming with their dog. A life jacket may be worn if desired. A wet suit may be helpful for extra buoyancy and to prevent accidental scratches from the dog while working in close proximity to the handler in the water. Swim fins make propulsion easier.

Dog Free Zone

Only the dog performing the Water Skills course may be in the beach area. The judge will designate a crating area or distance perimeter for all other participating dogs.

Personal space: Handlers should be observant of their dogs at all times and not put pressure on other dogs by greeting, sniffing or encroaching on another dog's personal space.

Safety and aggression: In the event the host, officiating judge or official feels that any dog or handler's behavior threatens the safety of the show grounds they will be directed to leave the show grounds.

Unsportsmanlike behavior: In the event the host, officiating judge or official feels that any person is acting in an unsportsmanlike manner they may be directed to leave the grounds.

*In the event a safety, aggression, threatening or unsportsmanlike situation occurs a report will be submitted by all acting officials to Wag It Games for review.

Hosts, Judges & Certified Instructors

Trial Hosts: Trial hosts may be individuals or businesses that have been approved by Wag It Inc. Applications to become a host are available at www.wagitgames.com.

Judges: Applications to become a Judge are available at www.wagitgames.com.

Certified Wag It Games Instructors: Our certified instructors have been approved based on their knowledge of dog behavior and positive reinforcement training methods as well as Wag it Games performance requirements. In addition certified instructors must demonstrate a strong ability to instruct individuals and groups in a supportive and encouraging manner. **Learning should always be fun for both dog and handler!** Information on becoming a certified Wag It Games instructor is available at www.wagitgames.com.

Participant Feedback: It is our goal to offer the best events possible. In the event a trial participant would like to offer a compliment for outstanding circumstances or file a complaint they may submit a Participant Feedback Form at any trial or directly to Wag It Inc, info@wagitinc.com.

Class Levels

Level titles must be completed to advance.

Novice, Entry level * **Skilled**, Intermediate level * **Proficient**, Advanced level

Class Divisions

Title Class: For dogs that have not yet earned the class level title.

Championship Class: For dogs that have earned their level title and are working on championship titles. Both class divisions run together but dogs only compete for placement against other dogs in their division.

Ribbons, Placements & Ties

Ribbon ceremony: A ribbon ceremony will follow each class.

Pass Fail: Hosts are required to offer qualifying score ribbons for each team that performs a qualifying level. Additional awards or prizes may be presented at the host's discretion.

Water Skills Titles

Please see individual skills division scoring rules for what defines a qualifying score.

WAG 1 W - Five qualifying scores in W, Novice Level

WAG 2 W- Five qualifying scores in W, Skilled Level

WAG 3 W- Five qualifying scores in W, Proficient Level

Water Skills Champion (WAG CH-W) – WAG 3 Sniff plus three additional qualifying scores at each level

Advanced Titles

Wag Master (Wag M)

Wag CH-Ball plus 3 additional qualifying scores at each level

Versatile Wag (V WAG)

Any three of the following titles: Wag M, WAG M-A, WAG M-W, WAG M-Sniff

WAG M-W=Water Skills WAG M-Sniff=Sniff It WAG M-A=Agility Skills

WAG M =Shadow, Independent & No Need for Speed Obstacle Skills

Points

Qualifying runs earn points as follows: Novice 5 points, Skilled 10 points, and Proficient 15 points.

Top 10 point earners for the year will be posted on the Wag It Games web site.

Performance Guidelines

Collars: On shore no type of training or correction collar including but not limited to choke chains, prong collars and head halters may be used. Standard harnesses are allowed but may not be designed to reduce pulling. Tags may be worn. Dogs may not wear collars while in the water. Dogs must wear life jackets. Shock collars are not allowed on the show grounds.

Leashes: Leashes must be made of leather, fabric or cord. They may have embellishments such as beading. Retractable leashes are not allowed in the ring or on show grounds. The dog must enter and leave the beach area on leash.

Rewards: Touch rewards may be offered at the completion of any exercise. No appearance of luring (giving any impression that food is being held) is allowed.

Timing: Each course will be a maximum course time. Timing will begin and end as designated in each exercise.

Harsh Corrections: Harsh corrections are not allowed in the ring or on the grounds. A harsh correction is one that results in a strong negative response from the dog or offends the sensibility of the judge. In the event harsh corrections are observed and depending on the severity, a warning may be issued or the parties involved may be asked to leave the grounds. An incident report on such occurrences will be submitted to Wag It Inc for review.

Equipment



Wag It Games recommends the Ruffwear Big Eddie Life jacket for dogs.

<http://www.ruffwear.com>

Wag It Games Water Skills

Novice Level

Teams must successfully perform all each class to earn a qualifying score.

Water Skills Swim Course Class

Exercise Objective

The objective of this exercise is for the dog to swim the course as directed by their handler. The handler may choose to walk or swim.

Retries

Mulligans: Handlers may retry one exercise per course without penalty. Any point deductions previously taken for that exercise will be erased.

Additional Retries: Handlers that choose to retry additional exercises will receive a deduction of -3 points per retry. Any point deductions taken for that exercise with the exception of prior retries will be erased. Retries do not erase Non-qualifying performances.

Side position: The dog is at the handlers side close enough to be under the handler's outstretched arm.

Front position: The dog is squarely facing the front of the handler. The dog should be close enough so the handler can reach out and touch the dog's head.

Course Requirements

Any calm fresh water lake or pond with a gradual increase of water depth may be used. Depth to be used for the course may vary from 4'-10'. The course area is approximately 10x30.

Floating markers will mark the course perimeters.

Time

The maximum course time is 5 minutes. Timing begins when the dog crosses the start line. Timing ends when the dog crosses the finish line.

Exercises

A steward will call out the exercises to the team.

Handlers may reward with t treat, toy or touch between exercises.

The Novice Course will consist of 8-10 exercises to include:

1-2, 180 Right or Left turns

1-2, Front Crosses

1, Pace change

1-2, 360 Right or Left turns

1-2, Right or Left turns.

1. Right Turn

The team performs a 90° turn to the right.

2. Left Turn

The team performs a 90° turn to the left.

3. 180 Right or Left (At the discretion of the handler)

The team performs a 180° turn to the right or Left.

4. 360 Right

The team performs a 360° circle to the right.

5. 360 Left

The team performs 360° circle to the left.

6. Front Cross

This is a change of sides exercise. The handler performs a 180° turn towards the dog while the dog performs a 180° turn towards the handler. (Thus the dog changes sides while the handler is viewing the dog's front). When the dog is in position on the new side they proceed.

7. Fast Pace

The team increases their speed so there is a noticeable change of pace. The team will maintain this pace change until they reach the Normal Pace sign.

8. Slow Pace

The team decreases their speed so there is a noticeable change of pace. The team must maintain this pace change until they reach the Normal Pace sign.

9. Normal

The team resumes their normal forward pace.

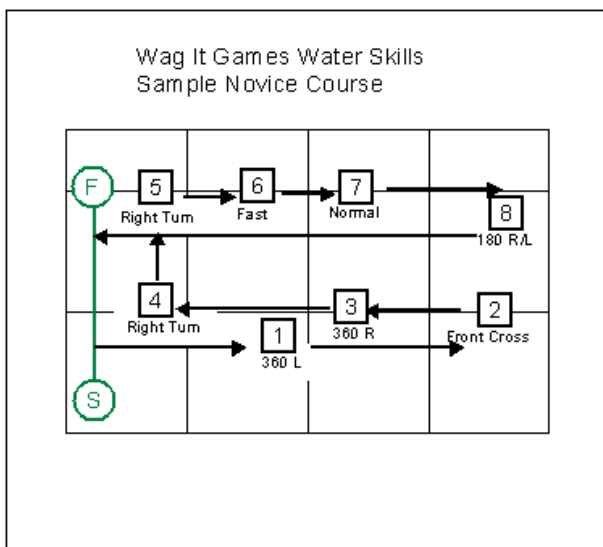

Wag It Games Water Skills Swim Course Scoring

Water Skills is a pass fail Skill Division.

Teams begin the course with a score of 100. Deductions are taken based on the exercise descriptions and scoring guidelines. Teams must receive a minimum score of 80 to qualify.

-1 point

- Out of position-lagging, forging or wide (dog is beyond the reach of the handler but less than 5' away.)

-3 points

- Significantly out of position-lagging, forging or wide (dog is more than 5' from the handler)
- Dog walks during the course instead of swimming.
- Retries: (Once the mulligan has been used.) Any deductions previously taken for that exercise will be erased with the retry. Retries are not erasable.
- Failure to maintain pace change
- Dog grabs up a buoy

-5 points

- Dog leaves the water briefly and returns to the handler. (Novice level only)
- Handler or dog perform an exercise in the wrong direction
- Excessive barking
- Failure to perform all the elements of an exercise as described

NQ

- Directing or controlling the dog by touching them.
- Failure of the handler to have the dog change sides in any side change exercise
- Failure to perform any exercise
- Luring (showing the dog a treat or toy to encourage the dog to perform.)
- Deductions of ten or more points on any exercise

Excusals - The following will result in a team being excused from the ring

- Dog appears to be overly stressed, in pain or ill
- Eliminating or vomiting on the beach or in the water
- Any appearance of threatening or aggressive behaviors
- Any behavior the Judge feels threatens safety in any way
- Harsh corrections

Skilled and Proficient Level information coming soon.